

## Greenpower DEUTZ diesel engine

---

1500 RPM

Type GP 20DZo

**Engine:** F3M2011

**Alternator:** ECO28-1L/4

The engine with external oil cooling system.

These are the characteristics of the 2011 Gen:

- 3 cylinder naturally aspirated in line engines.
- 4 cylinder model also with turbocharging.
- Displacement: 0.78 l/cylinder.
- Fully oil-cooled (engine with conventional cooling system)
- Acoustically optimized crankcase.
- All service points on the same engine side.
- Electronic engine governor (option).
- Compact design and low weight.
- Worldwide service network with over 1,000 locations.

### Your benefits:

- ▶ Low noise emission, cost savings as no noise attenuation measures are required.
- ▶ Long oil change intervals: 1,000-hour / turbocharged engines 500 hour and low fuel consumption bring savings in operating cost.
- ▶ Low installation cost.  
Excellent load takeover characteristics ensure prompt power supply.
- ▶ Combined oil cooling and lubrication prevents corrosion and cavitation.  
High reliability and durability together with reduced maintenance requirement and wear parts.

## ► Rating table: 2011. The Genset Engine. 50 Hz

Engine type	F3M2011	
Speed	min <sup>-1</sup>   rpm	1500
Frequency	Hz	50
<b>Engine/genset ratings <sup>1)</sup></b>		
Continuous power, ICN (COP) <sup>2)</sup>	kW   hp	18.5   25.2
Prime power, ICN (PRP) <sup>3)</sup>	kW   hp	19.4   25.4
Limited-time running power, IFN (LTP) <sup>4)</sup>	kW   hp	20.4   27.7
<b>Typische Generatorleistung</b>		
Typical generator power output (COP) <sup>5)</sup>	kVA	19.0
Typical generator power output (PRP) <sup>5)</sup>	kVA	20.0
Typical generator power output (LTP) <sup>5)</sup>	kVA	20.9
<b>Spec. fuel consumption PRP (LTP)<sup>6)</sup></b>		
100% load	g/kWh   lb/hp-hr	225   0.365
75% load	g/kWh   lb/hp-hr	230   0.373
50% load	g/kWh   lb/hp-hr	245   0.397
25% load	g/kWh   lb/hp-hr	400   0.648

### Standard Specification:

Standard engine: Flywheel housing SAE 3; flywheel with 11.5" connection.

Cooling system: Cooling unit, V belt guard, pusher type fan.

Filter: Dry air cleaner with mechanical restriction indicator, fuel filter.

### Scope of Supply:

The engine and the alternator are mounted together forming a rigid monoblock, the shafts are connected by a flexible disc connection. The monoblock is mounted on a steel base frame via silent blocks. The base frame is including a fuel tank. Starting is electric and it includes a battery. The genset monitoring system consist of a control module.

#### PRP\* Kva/KW:

Available electrical power (at a variable load) with a medium of 80% of the indicated maximum power. A 10% overload capability is available

#### LTP\*\* Kva/KW:

Available electrical load (at a variable load) during a maximum of 500 hours per year. No overload capability is available.

## CONTROL PANEL

Manual or automatic start control panel

Manual or automatic remote boot controller, selector switch for Off, Man and Auto with the key.

Complete motor protection functions with alarms visualized via LEDs in the front.

The control unit 6 is set via DIP switches in the rear part of the case.

Standard circuit breaker and differential relay.

TECHNICAL DATA

Engine		Alternator	
Engine type:	F3M2011	Alternator Type:	ECO28-1L/4
Eng. Power kW COP:	18,1	Nº of poles:	4
Eng. Power kW PRP:	19	Eff. At 3/4 %:	88
Eng. Power kW LTP:	20	Eff. At 4/4 %:	87,6
Nº Cylinders:	3	Alt. rating PRP kVA III Kw II:	20
Displacement cm3:	2330	Alt. rating LTP kVA III kW II:	22
Bore/stroke (mm/mm):	94/112	Output Power PRP kVA III kW II:	20
Compression ratio:	17,5	Output Power LTP kVA III kW II:	21,9
Cooling:	OIL	Current Amp PRP:	28,8
Injection:	DIRECT	Current Amp LTP:	31,4
Aspiration:	NATURAL	Standard Circuit Breaker (Amp):	32 IV
Standard governor:	MECHANICAL	Xd (%):	175
Governing control quality:	G2	X'd (%):	16,5
Speed droop mech gov. (%):	4-5	X:	9,4
Exhaust gases temperature (°C):	510	Nº of wires:	12
Exhaust gases flow (m3/h):	230	Insulation:	H
Max Exh. Back pres. (mbar):	30	Regulator AVR:	SR7/2
Coolant capacity (lit.):	5,5	Protection:	IP23
Cooling air flow (m3/h):	1800		
Max allow. Intake dep. (mbar):	20		
Combustion air flow (m3/h):	86		
Oil cap. (Litres):	5,5		
Oil cons. (kg/hr or % of fuel cons):	0,30%		
Min oil press warning (bar):	2,1		
Fuel cons. 25% lit/h:	2,3		
Fuel cons. 50% lit/h:	2,9		
Fuel cons. 75% lit/h:	3,9		
Fuel cons. 100% lit/h:	5,0		
Electric system VDC:	12		
Type:	Neg to ground.		
Battery (Ah):	60		
Starting motor (kW):	3		
Flywheel Housing:	SAE3/11,5		

## ► Engine Description

Type of cooling:.....	Integrated oil cooling
Crankcase:.....	Grey cast iron
Crankcase breather:.....	Closed-circuit breather
Cylinder head:	Block-type cast iron cylinder head
Valve arrangement/ Timing: .....	Overhead valves in cylinder head, one inlet and one exhaust valve per cylinder, actuated via tappets, push rods and rocker arms, driven by toothed belt and camshaft, automatic tensioner.
Piston: .....	Three-ring piston, two compressions rings and one oil scraper ring
Piston cooling:.....	Oil-cooled with spray nozzles
Connectingrod: .....	Drop-forged steel rod
Crankshaft and big-end bearings:.....	Ready-to-install plain bearings
Crankshaft: .....	Modular cast iron
Camshaft:.....	Steel shaft in bi-metal bearings
Lubrication system:	Forged-feed circulation lubrication with rotary pump which feeds both lubrication and cooling systems (and cab heating if fitted)
Lube oil cooler:.....	Integrated, of light metal
Lube oil filter:.....	Paper-type micro-
injection pump/ Governor: .....	Single injection pumps
Fuel lift pump: .....	Serviceable, with integrated
injection nozzle:.....	Five-hole nozzle
Fuel filter: .....	Replaceable cartridge
Alternator: .....	Three-phase alternator, 14 V; 60 A (Standard)
Starter motor:.....	2,3 kW; 12 V
Heating system:.....	Optional connection for cab heating
Options:.....	Intake manifold connections, exhaust manifolds connections, hydraulic pumps, engine mounts rigid and flexible, oil pans, dipsticks, SAE 3/4/5/6 flywheel housings, alternators 12 and 24 V, oil filter positions horizontal and vertical, oil filler neck on side of crankcase or cylinder head cover

# Engine Description

Operation Side

## F3M2011

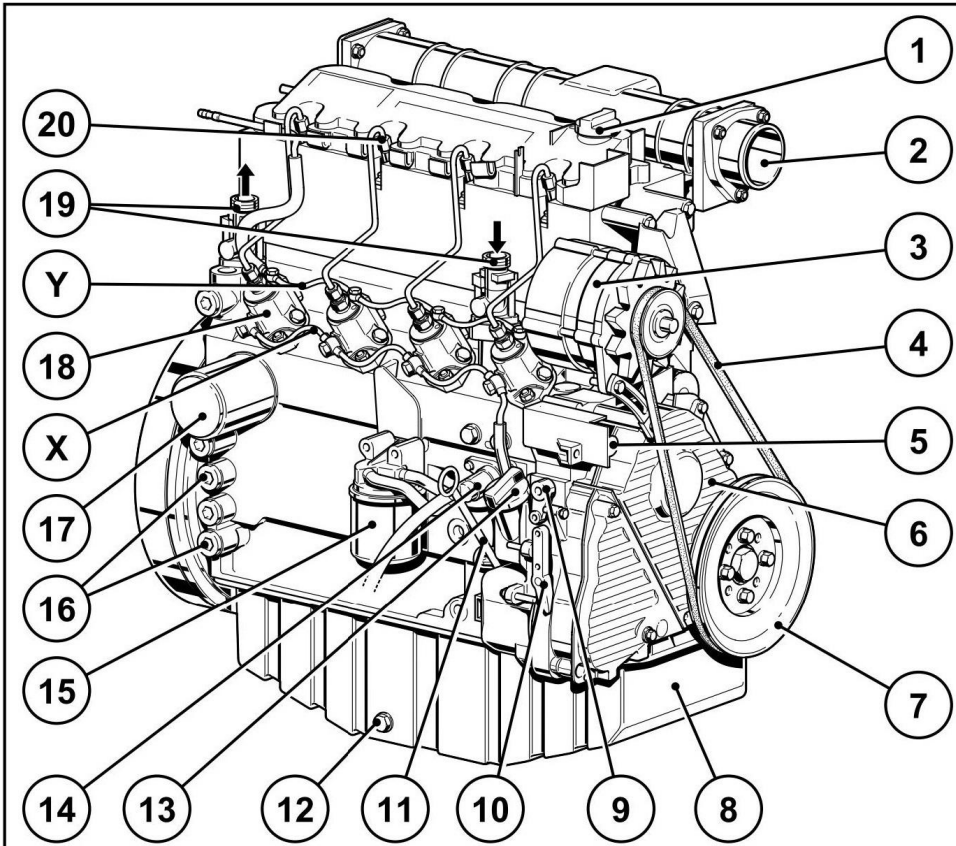

- 1 Oil filler neck (valve-gear housing cover)
- 2 Charge-air line / air-intake line
- 3 Alternator
- 4 Narrow V-belt
- 5 Tractive electromagnet
- 6 Timing belt cover
- 7 V-belt pulley on crankshaft
- 8 Oil pan
- 9 Shut-off lever
- 10 Speed control lever
- 11 Oil dipstick
- 12 Oil drain plug
- 13 Oil fill point (on side of crankcase)
- 14 Fuel pump
- 15 Easy-change fuel filter
- 16 Connecting facility for oil heater
- 17 Lube oil replacement filter
- 18 Injection pump(s)
- 19 Oil cooler connection
- 20 Injection valve(s)
- X fuel to run line
- Y fuel back run line

## Engine Illustration

Exhaust Side

### F3M2011

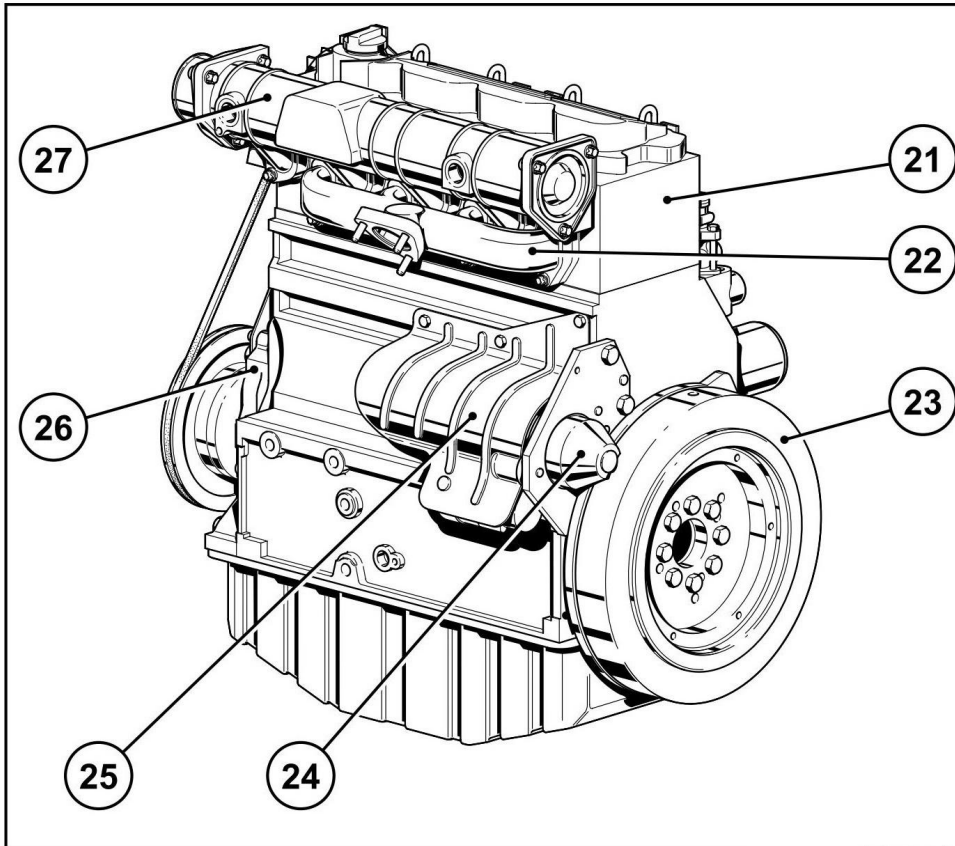

- 21 Cylinder head
- 22 Exhaust manifold
- 23 Flywheel with ring gear
- 24 Starter
- 25 Starter guard (optional)
- 26 Crankcase
- 27 Air intake pipe



### Greenpower AB

Helsingborgsvägen Varalöv  
262 96 Ängelholm, Sweden  
Tel: +46 431-222 40  
E-mail: [info@greenpower.se](mailto:info@greenpower.se)  
web: [www.greenpower.se](http://www.greenpower.se)